

SCALE: 1:1.5

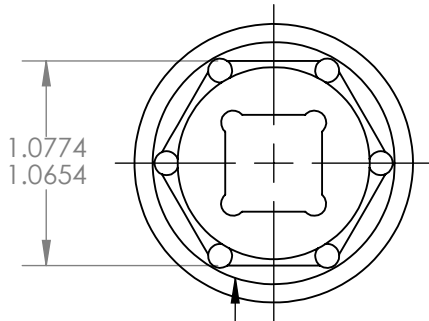

1.0774
1.0654

CHAMFER .01 X 60° MIN
PAST CORNER DRILL EDGES

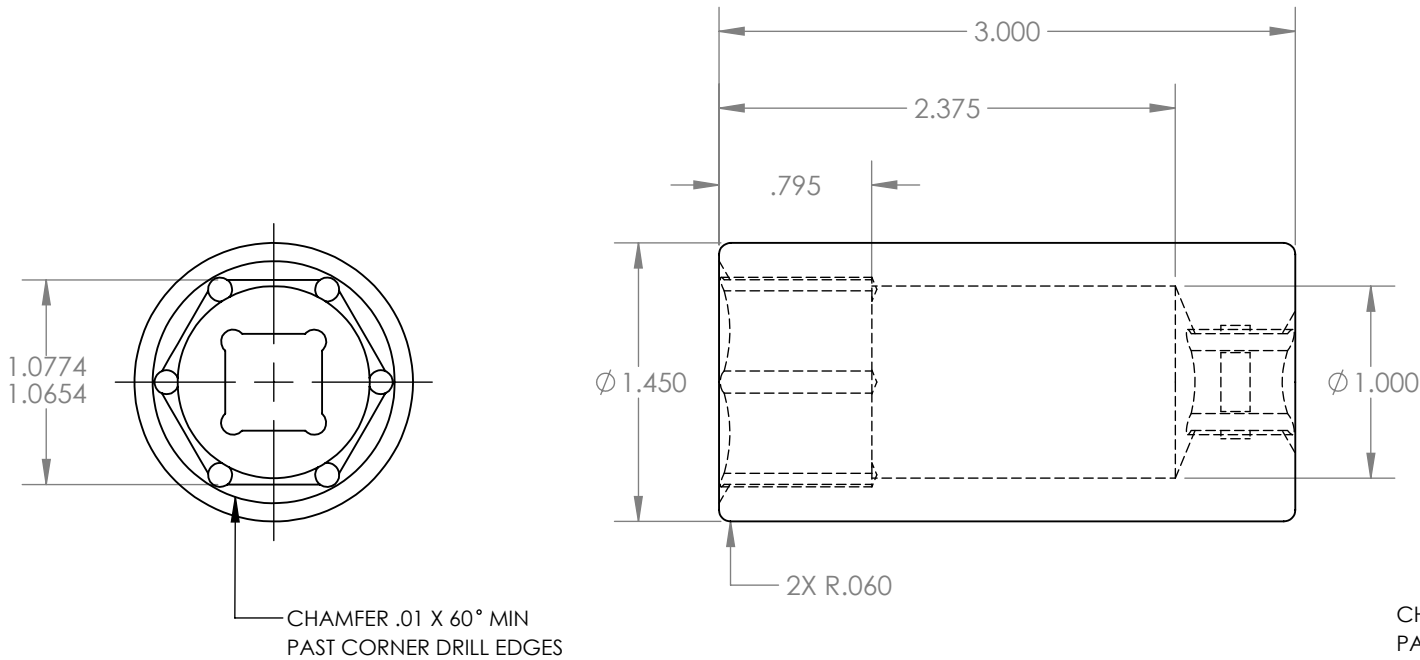
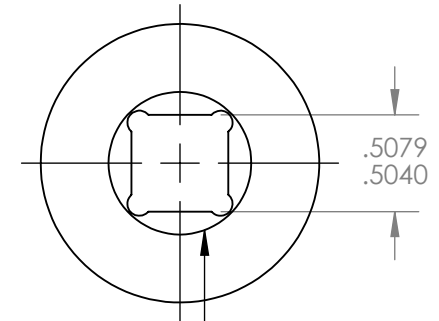

.5079
.5040

CHAMFER .01 X 60° MIN
PAST CORNER DRILL EDGES

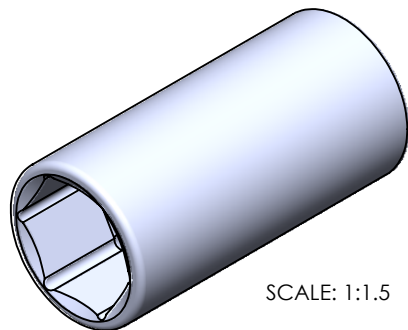

SCALE: 1:1.5

UNLESS OTHERWISE SPECIFIED: DIMENSIONS ARE IN INCHES			TOLERANCES: X.XX= ±0.13 X.XXX= ±0.015 X.XXXX= -0.0015		
DRAWN	NAME	SIGN	DATE		
APP'VD	A.T.		06.18.19		
MATERIAL: 17-4 MAGNETIC S.S.					TITLE: 1-1/16" X 1/2" DRIVE DEEP SOCKET
<i>THIS DRAWING IS THE PROPERTY OF STERITOOL, INC. ANY REPRODUCTIONS OR MODIFICATIONS OF THIS DRAWING OR ITS CONTENTS WITHOUT THE CONSENT OF STERITOOL, INC. IS PROHIBITED.</i>					PART NO. 10655
					SCALE: 1:1